

# Data Sheet



Article number: 2308051561

Description: E+G Index plunger  
PMT.100-SST-8-M16x1.5-A

## Measures

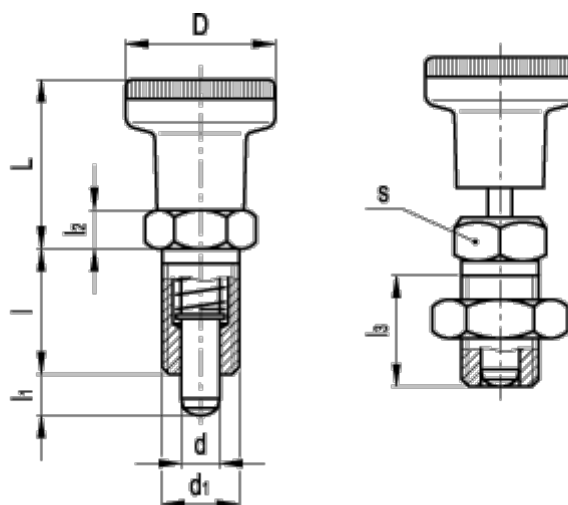

Code = PMT.100-8-M16x1,5-SST-A

D = 31

d = 8

d1 = M16x1.5

l = 26

L = 35

l1 = 8

l2 = 8

l3 = 23

Max. axial load (N) = 26

s = 19